

FLORAL DRESDEN PLATE

You need: White – a 12 ½ inch square for background

Floral(s) – one strip 5" by 15" (or 6 scraps 5" by 3.5") and a 3" circle

Solid(s) – one strip 5" by 15" or 6 scraps 5" by 3.5"

Cut six wedges of the template from the floral. See diagram 1. Cut six of the template from the solid. You should have 12 total petals, half floral and half solid.

Fold each petal in half length-wise (hot dog fold) rst. Sew a ¼ inch seam across the larger end, perpendicular to the fold. See diagram 2. Pinch the fold into a crease. Unfold the petal. Make the short seam you sewed line up with the crease. Press the petal flat. See diagram 3. Sew all remaining 11 petals in the same manner.

Sew the petals together in pairs, a floral on bottom, a solid on top, rst. It is important to be consistent here so that when you open each sewn pair, the floral is on your left and the solid on your right. If any two petals are not the same length, line up the top edges and leave any unevenness at the short, bottom edge. Sew pairs to make foursomes, and so on until you have a circle.

Fold the background block in half and make a small crease at either end of the fold to mark the center of those two sides. Unfold, and fold in half the other way to crease and mark the centers of the other two sides. Unfold.

Lay the circle of petals on the background, using the creases to center it. There should be a petal pointing to each crease. Place a pin in each petal. Sew (by hand or machine) on the outside edges of the circle to adhere it to the background. Now cut out a circle of floral. Sew the circle, rst, to a dryer sheet with a ¼ inch seam, all the way around. CAREfully, cut a slit in the dryer sheet ONLY. Turn the circle right side out, running your finger or a crochet hook around the seam line to open it fully. Press. Pin it over the center of the dresden plate. Sew it in place. See diagram 4.

For more diagrams see: <http://www.quilterbydesign.com/lessons/dresdens/dresdens.html>

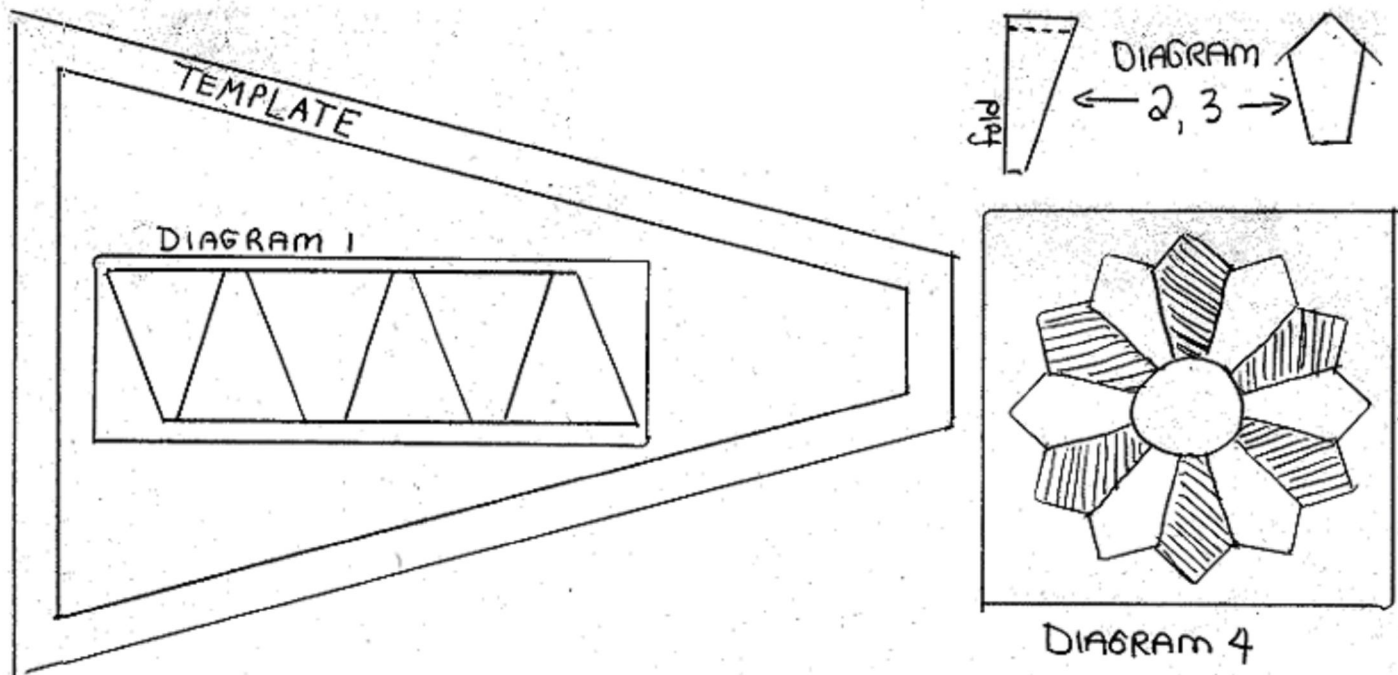

If your wedge is not exactly 5" long, that is OK. Just always align the same end (the short one) against the edge of the fabric, and extend the cutting line to the edge of the fabric."